



TRUE FOOD SERVICE EQUIPMENT, INC.

St. Charles Industrial Center • P.O. Box 970 • O'Fallon, Missouri 63366
 (636)240-2400 • FAX (636)272-2408 • (800)325-6152 • www.truemfg.com
 Parts Dept. (800)424-TRUE • Parts Dept. FAX# (636)272-9471

Project Name: _____

A/A #

Location: _____

Item #: _____ Qty: _____

SIS #

Model #: _____

Model:
TUC-48F-D-4

Undercounter:
Drawered Freezer



TUC-48F-D-4

- ▶ True's undercounter units are designed with enduring quality that protects your long term investment.
- ▶ Designed using the highest quality materials and components to provide the user with colder product temperatures, lower utility costs, superior food safety and the best value in today's food service marketplace.
- ▶ Oversized, environmentally friendly (R404A) forced-air refrigeration system holds -10°F (-23.3°C). Ideally suited for both frozen foods and ice cream.
- ▶ All stainless steel front, top and cabinet ends. Matching aluminum finished back.
- ▶ Front breathing.
- ▶ Each drawer accommodates one (1) fullsize 12" L x 18" W x 6" D (305 mm x 458 mm x 153 mm) food storage box (sold separately).
- ▶ Foamed-in-place, high density polyurethane insulation (CFC free).

ROUGH-IN DATA

Specifications subject to change without notice.
 Chart dimensions rounded up to the nearest 1/8" (millimeters rounded up to next whole number).

Model	Drawers	Capacity (Cu. Ft.) (liters)	Cabinet Dimensions (inches) (mm)			HP	Voltage	Amps	NEMA Config.	Cord Length (total ft.) (total m)	Crated Weight (lbs.) (kg)
			L	D†	H*						
TUC-48F-D-4	4	12.0 340	48 ³ / ₈ 1229	30 ¹ / ₈ 766	29 ³ / ₄ 756	1/2	115/60/1	10.9	5-15P	7 2.13	355 162

† Depth does not include 1" (26 mm) for rear bumpers.
 * Height does not include 6 1/4" (159 mm) for castors or 6" (153 mm) for optional legs.



APPROVALS:

Model:
TUC-48F-D-4

Undercounter:
Drawered Freezer



STANDARD FEATURES

DESIGN

- True's commitment to using the highest quality materials and oversized refrigeration systems provides the user with colder product temperatures, lower utility costs, superior food safety and the best value in today's food service marketplace.

REFRIGERATION SYSTEM

- Factory engineered, self-contained, capillary tube system using environmentally friendly (CFC free) R404A refrigerant.
- Oversized, factory balanced refrigeration system with guided airflow to provide uniform product temperatures.
- Extra large evaporator coil balanced with higher horsepower compressor and large condenser; maintains -10°F (-23.3°C) cabinet temperatures. Ideally suited for both frozen foods and ice cream.
- Sealed, cast iron, self-lubricating evaporator fan motors and larger fan blades give True undercounter units a superior low velocity, high volume airflow design. This unique design insures faster temperature recovery and shorter run times in the busiest of foodservice environments.
- Condensing unit access in back of cabinet, slides out for easy maintenance.
- Automatic defrost system time-initiated, time-terminated.

CABINET CONSTRUCTION

- Exterior - stainless steel front, top and cabinet ends. Matching aluminum finished back.
- Interior - attractive, NSF approved, white aluminum liner. 300 series stainless floor with coved corners.
- Insulation - entire cabinet structure and drawer facings are foamed-in-place using high density, CFC free, polyurethane insulation.
- 5" (127 mm) diameter stem castors - locks provided on front set. 36" (915 mm) work surface height.

DRAWERS

- Stainless steel exterior with white aluminum liner to match cabinet interior.
- Each drawer fitted with 12" (305 mm) long recessed handle that is foamed-in-place with a sheet metal interlock to insure permanent attachment.
- Magnetic drawer gaskets of one piece construction, removable without tools for ease of cleaning.

PAN CAPACITY

- Each drawer accommodates one (1) full size 12"L x 18"W x 6"D (305 mm x 458 mm x 153 mm) food storage box or one 1/3 size and one 1/2 size pans (sold separately).
- Heavy-duty stainless steel drawer slides and rollers. Removable without tools for easy cleaning.

MODEL FEATURES

- Evaporator is epoxy coated to eliminate the potential of corrosion.

ELECTRICAL

- Unit completely pre-wired at factory and ready for final connection to a 115/60/1 phase - 15 amp dedicated outlet. Cord and plug set included.



115/60/1
NEMA-5-15R

OPTIONAL FEATURES/ACCESSORIES

Upcharge and lead times may apply.

- 6" (153 mm) standard legs.
- 6" (153 mm) seismic/flanged legs.
- 2 1/2" (64 mm) diameter castors.
- Basic overshef.
- Sandwich/salad service shelf.
- Single utility shelf.
- Double utility shelf.
- 30" (762 mm) deep, 1/2" (13 mm) thick, white polyethylene cutting board. Requires "L" brackets.
- 30" (762 mm) deep, 1/2" (13 mm) thick, composite cutting board. Requires "L" brackets.
- Heavy duty, 16 gauge tops.
- ADA compliant models with 34" (864 mm) work surface height.
- Low profile models with recessed castors. 31 1/2" (801 mm) work surface height.
- Remote cabinets (condensing unit supplied by others), consult factory technical service department for BTU information.

PLAN VIEW

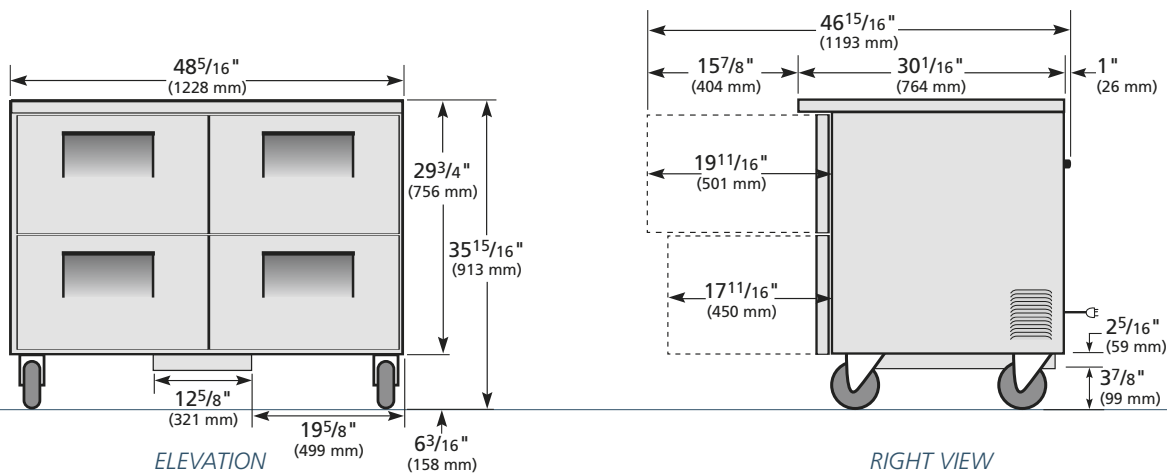

WARRANTY

One year warranty on all parts & labor and an additional 4 year warranty on compressor. (U.S.A. only)

METRIC DIMENSIONS ROUNDED UP TO THE NEAREST WHOLE MILLIMETER
SPECIFICATIONS SUBJECT TO CHANGE WITHOUT NOTICE



Model	Elevation	Right	Plan	3D
TUC-48F-D-4	TFQY06E	TFQY05S	TFQY06P	TFQY063

TRUE FOOD SERVICE EQUIPMENT

St. Charles Industrial Center • P.O. Box 970 • O'Fallon, Missouri 63366 • (636)240-2400 • FAX (636)272-2408 • (800)325-6152 • www.truemfg.com