



**TRUE FOOD SERVICE
EQUIPMENT, INC.**

2001 East Terra Lane • P.O. Box 970 • O'Fallon, Missouri 63366
(636)240-2400 • FAX (636)272-2408 • (800)325-6152 • www.truemfg.com
Parts Dept. (800)424-TRUE • Parts Dept. FAX# (636)272-9471

Project Name: _____

Location: _____

Item #: _____ Qty: _____

Model #: _____

A/A #

S/S #

Model:
TA2HPT-2S-2S

TA Specification Series:
Pass-Thru Solid Door Heated Cabinet



TA2HPT-2S-2S

- ▶ Provides cabinet holding temperature of 80°F to 180°F (26.6°C to 82.2°C).
- ▶ Cabinet equipped with 2 low velocity fans to assure even temperature distribution throughout the cabinet. Fans are controllable by exterior on/off switch.
- ▶ Two (2) stainless steel (for corrosion resistance), finned tube heating elements (1000 watts each) per section for uniform generation of electric heat. Cabinet comes with a total of 4000 watts.
- ▶ 300 series stainless steel exterior front, sides back and bottom. The very finest stainless; higher tensile strength for fewer dents and scratches.
- ▶ Anodized aluminum interior cabinet liner. 300 series stainless steel door liner and floor with coved corners.
- ▶ Six (6) adjustable, heavy duty chrome shelves with wall mounted pilasters.
- ▶ Entire cabinet structure and solid doors are foamed-in-place using high density, CFC free, polyurethane insulation.
- ▶ Positive seal self-closing doors with 120 degree stay open feature. Lifetime guaranteed door hinges and recessed door handles.

ROUGH-IN DATA

Specifications subject to change without notice.
Chart dimensions rounded up to the nearest 1/8" (millimeters rounded up to next whole number).

Model	Doors	Capacity (Cu. Ft.) (liters)	Cabinet Dimensions (inches)			Watts	Voltage	Amps	Crated Weight (lbs.) (kg)
			L	D†	H*				
TA2HPT-2S-2S	4	56	51 ³ / ₈	37 ¹ / ₄	78 ¹ / ₄	4000	115/208-240/60/1	16.8	600
		1586	1305	947	1988				273

† Depth does not include 1¹/₈" (29 mm) for system mechanical components.

* Height does not include 6¹/₈" (156 mm) for legs and 1" (26 mm) for system mechanical components.

Requires 115/208 -240/60 Hz, single phase, 3 pole, 4 wire circuit.



APPROVALS:

AVAILABLE AT:

Model:
TA2HPT-2S-2S

TA Specification Series:
Pass-Thru Solid Door Heated Cabinet



STANDARD FEATURES

DESIGN

- True's solid door pass-thru heated cabinets are designed with enduring quality that protects your long term investment.

HEATER SYSTEM

- Cabinet is designed to provide holding temperatures of 80°F to 180°F (26.6°C to 82.2°C). Heating system controlled by exterior on/off switch and temperature control dial.
- Two (2) stainless steel (for corrosion resistance), finned tube heating elements (1000 watts each) per section for uniform generation of electric heat. Cabinet comes with a total of 4000 watts.
- Cabinet equipped with 2 low-velocity fans to assure even temperature distribution throughout the cabinet. Fans are controllable by exterior on/off switch.
- Manually controlled vent located on top of the cabinet for positive humidity control.
- Exterior dial thermometer; accurate direct reading of internal cabinet temperature.

CABINET CONSTRUCTION

- Exterior - 300 series stainless steel doors, front, sides, back and bottom.
- Interior - anodized aluminum liner. 300 series stainless floor with coved corners.
- Stainless steel breaker caps.
- Insulation - entire cabinet structure and solid doors are foamed-in-place using high density, CFC free, polyurethane insulation.
- Welded heavy duty galvanized frame rail dipped in rust inhibiting enamel paint for corrosion protection inside and out.
- Frame rail fitted with 6" (153 mm) stainless steel legs.

DOORS

- 300 series stainless steel exterior and door liner. Doors open within cabinet dimension. Door locks standard.

- Lifetime guaranteed recessed door handles. Each door fitted with 12" (305 mm) long recessed handle that is foamed-in-place with a sheet metal interlock to insure permanent attachment.
- Positive seal self-closing doors with 120 degree stay open feature. Lifetime guaranteed door hinges and torsion type closure system.
- Magnetic door gaskets of one piece construction, removable without tools for ease of cleaning.

SHELVING

- Six (6) adjustable, heavy duty chrome shelves 23¹/₂" L x 28¹³/₁₆" D (597 mm x 732 mm) with shelf clips and wall mounted pilasters (factory installed). 1¹/₁₆" (27mm) standoff insures optimum airflow.
- Aluminum shelf support pilasters; shelves are adjustable on 1/2" (13 mm) increments.
- Three (3) different interior kits available (see Kit Options). Pilasters and tray slides require field installation.

LIGHTING

- Incandescent interior lighting; safety shielded. Lights activated by exterior on/off switch.

MODEL FEATURES

- True heated cabinets are designed to hold warm baked or cooked food. Cabinets are not designed to heat ambient or cold product.
- NSF-4 compliant for open food product.

ELECTRICAL

- True requires that a sole use circuit be dedicated for the unit.
- Unit comes with 4 feed wires (including ground) to be hardwired at installation site to a 115/208-240/60 Hz. single phase - 20 amp dedicated outlet.

OPTIONAL FEATURES/ACCESSORIES

- Upcharge and lead times may apply.
- Seismic/flanged legs.
- Stainless steel rail skirt for use with legs (field installed).
- Additional chrome shelves.
- Metal door handle.
- Stainless steel (electro polished) shelves.
- Electronic temperature control (factory installed).
- Correctional facilities options - consult factory.
- Curb mountable units.

KIT OPTIONS

- Kit #1: Nine (9) sets of #1 type tray slides and pilasters (field installed), bottom support of one (1) 18"L x 26"D (458 mm x 661 mm) pan or two (2) 14"L x 18"D (356 mm x 458 mm) pans.
- Kit #2: One (1) set half-section #2 steel rod tray slides and pilasters (field installed), rim support of one (1) 18"L x 26"D (458 mm x 661 mm) pan.
- Kit #3: Six (6) sets of universal type tray slides and pilasters (field installed), bottom support of one (1) 18"L x 26"D (458 mm x 661 mm) pan, two (2) 12"L x 20"D (305 mm x 508 mm) pans or two (2) 14"L x 18"D (356 mm x 458 mm) pans.
- Additional kit option components available individually.

PLAN VIEW

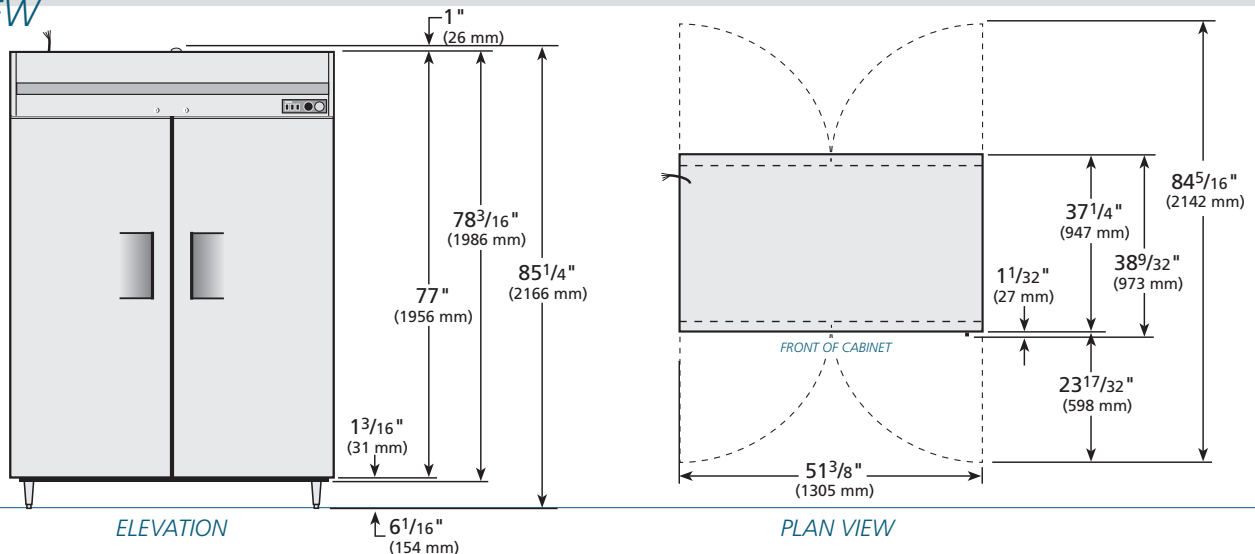

WARRANTY

One year warranty on all parts & labor (U.S.A. only)

METRIC DIMENSIONS ROUNDED UP TO THE NEAREST WHOLE MILLIMETER

SPECIFICATIONS SUBJECT TO CHANGE WITHOUT NOTICE



Model	Front	Side	Plan	3D
TA2HPT-2S-2S	TFQY180E	TFQY196S	TFQY196P	TFQY1963

TRUE FOOD SERVICE EQUIPMENT

2001 East Terra Lane • P.O. Box 970 • O'Fallon, Missouri 63366 • (636)240-2400 • FAX (636)272-2408 • (800)325-6152 • www.truemfg.com